



Shadow & Breeze Awnings

The shed style **Shadow** and **Breeze** Awnings are stationary awnings designed for year-round installation with minimal maintenance. The **Shadow** has closed sides, a six inch rigid valance and can be used for both window and door applications. The **Breeze** is an open sided unit with a six inch loose valance and is for window application only. Both awnings block the sun's direct light and reduces radiant heat absorption which has been shown to lower air conditioning bills and prevent unnecessary replacement costs of furnishings.

Special Features and Benefits Include:

- Stationary awning
- Functional door and/or window accent
- Traditional look for homes and businesses
- Available in six popular colors
- Easy to follow installation instructions
- Virtually maintenance free
- Packed specially for reduced shipping costs

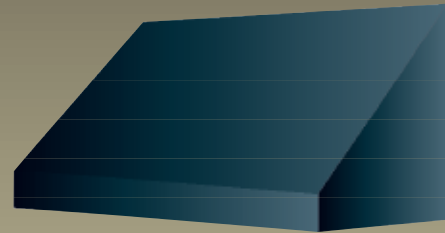

The Shadow
Door and Window Awning



The Breeze
Window Awning



800.444.6131 • www.durasol.com
38 Pond Lane, Suite B • Middlebury, VT 05753

Shadow & Breeze Awnings

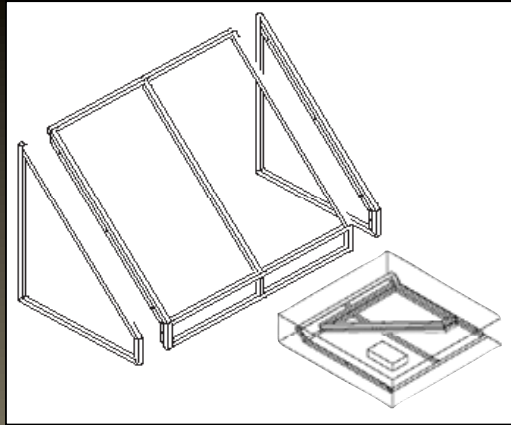

The Shadow
Door and Window Awning

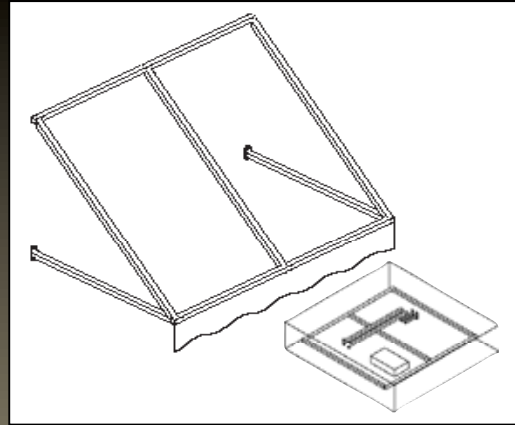

The Breeze
Window Awning

The Shadow and the Breeze ship ready to assemble with fabric attached.

PRODUCT OVERVIEW*

Primary Application: **Windows and Doors**

Width Ranges	Window: 42", 54" and 90" Door: 40" and 48"
Drop & Projection Range	Window: 30" Drop/36" Projection Door: 18" Drop/42" Projection
Frame	Welded stationary awning
Frame Finish	Standard mill finish aluminum
Mounting Options	Wall surface
Fabric Options	100% Acrylic Fabric colors shown below
Warranty	10 years - Framework 5 years - Manufacturers Standard Fabric Warranty
Unit Color Options	 Burgundy Forest Green Toast Taupe Evergreen Front Licorice

*Subject to change without prior notice

GO GREEN on Energy Cost!



Go Green and Reduce Energy Cost

Durasol retractable awnings effectively filter the sun's light creating a cool and relaxed environment. Solar heat gain is greatly reduced by limiting the amount of direct sunlight that enters a window or door.

The use of fabric awnings will **reduce solar heat by up to 90%*** and lower indoor temperatures by 10-15%, thus saving 25%* on air conditioning costs throughout the warmer months.

*Source: 2007 PAMA

DURASOL
AWNINGS
Your Total Shading Solution™

800.444.6131 · www.durasol.com

38 Pond Lane, Suite B · Middlebury, VT 05753